

# Battery Burnisher

Model:  
M27000-00  
M27000-00 CE

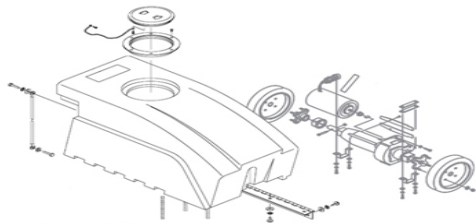

**FLOOREQUIPMENTPARTS.COM**

**OPERATION**

**SERVICE**

**PARTS**

**CARE**

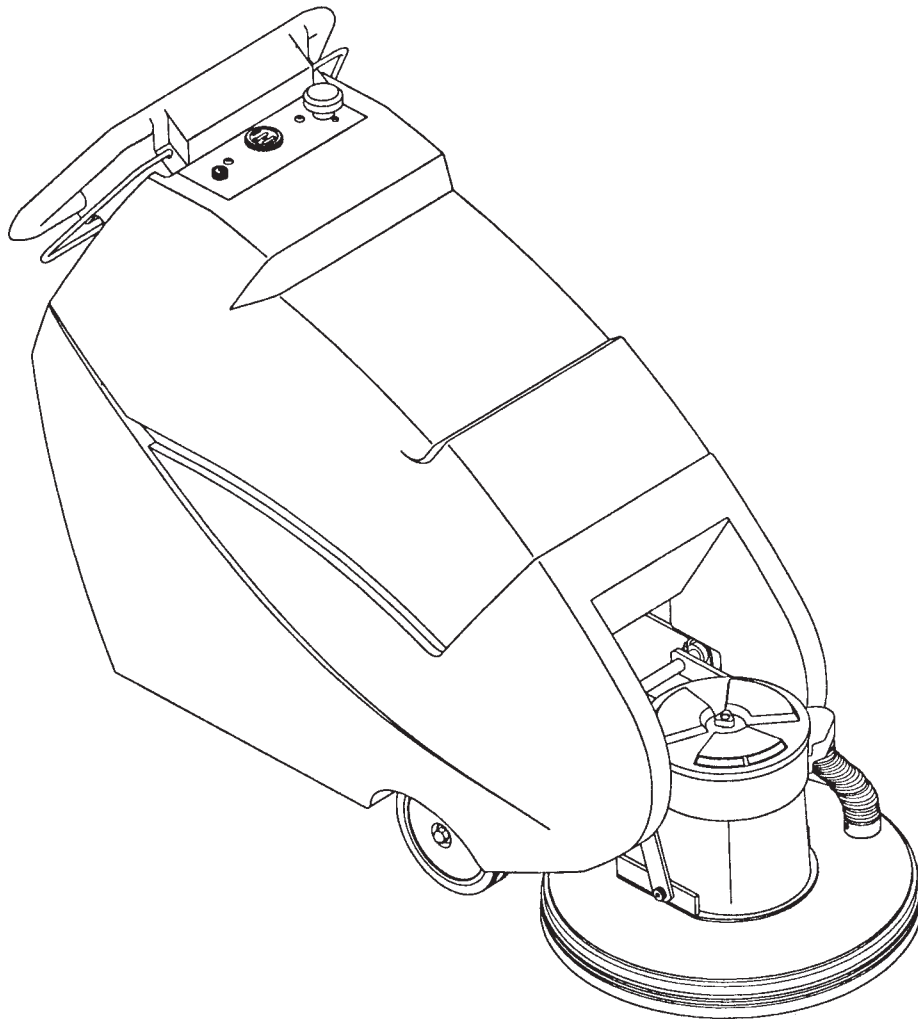

Revised 7/02

**Minuteman<sup>®</sup>**

# EC Declaration of Conformity

according to Directives 89/392, 89/336, 72/73

We, Minuteman International Incorporated, of 111 South Rohlwing Road Addison Illinois 60101 USA, declare under our sole responsibility that the product M27000-00CE Commercial Battery Burnisher to which this declaration relates corresponds to the relevant requirements of the EC Directives 89/392, 89/336 and 72/73. The following standards were used to determine compliance with the Directives: EN 292, EN 294, EN 811, EN 55011, EN 55104, EN 50082-2, EN 60335-1 and IEC 335-72.

<b>SOUND</b>		<b>VIBRATION</b>									
<b>72 dB Operator</b>	<b>69 dB At 3m</b>	<b>.55 m/s<sup>2</sup> At Operators Hand Grips</b>									
Tests were conducted on 11/25/97 with calibrated sound and vibration equipment under the conditions noted below: <table style="width: 100%; margin-top: 10px;"> <tr> <td style="width: 33%;">General Condition: Sunny</td> <td style="width: 33%;">Wind: 8 km/hr</td> <td style="width: 33%;"></td> </tr> <tr> <td>Temperature: 10°C</td> <td>Humidity: 60%</td> <td></td> </tr> <tr> <td>Barometric Pressure: 29.0</td> <td></td> <td></td> </tr> </table>			General Condition: Sunny	Wind: 8 km/hr		Temperature: 10°C	Humidity: 60%		Barometric Pressure: 29.0		
General Condition: Sunny	Wind: 8 km/hr										
Temperature: 10°C	Humidity: 60%										
Barometric Pressure: 29.0											

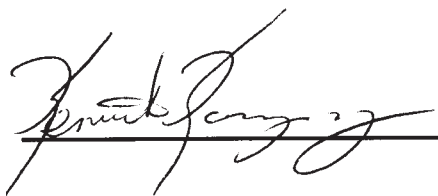

*Kenneth Kaczmarz, Standards Engineer*

11/25/97

*Date*

# CONTENTS

## ILLUSTRATION, SPARE PARTS, OPERATION & SERVICE

PRECAUTIONS .....	1
OPERATION & INSPECTION .....	2
PAD INSTALLATION & ADJUSTMENTS .....	3-8
BATTERIES .....	9
MACHINE OVERVIEW, CONTROL PANEL DIAGRAM .....	10
MAIN FRAME ASSEMBLY .....	11-12
DRIVE UNIT ASSEMBLY .....	13-14
HANDLE ASSEMBLY .....	15-16
ELECTRICAL ASSEMBLY .....	17-20
WARRANTY POLICY .....	Back Cover

# ***IMPORTANT SAFETY INSTRUCTIONS***

## **CAUTION:**

Operators must read and understand this manual before operating or maintaining this machine.

Keep hands and feet clear of moving parts while machine is in operation.

Disconnect the power to the machine by pressing the red Emergency Disconnect Button when charging batteries or during installation or removal of pads.

During operation, loose objects on the floor can become dangerous projectiles if struck by the high speed pad. Special attention should be paid in removing or avoiding loose floor tile, electrical cables, telephone connection boxes.

Electrical motors and components can cause an explosion when operated near explosive materials or vapors. Do not operate this machine near flammable materials such as solvents, thinners, fuels, grain dust, etc.

Keep machine moving to reduce the risk of damaging floor finish and floor.

Make sure the red Emergency Disconnect Button is pressed and the battery connector is unplugged from the machine before performing any maintenance procedures.

Store or park this machine on a level surface only.

These machines are designed for level floor operation only. *Do not operate on ramps or inclines.*

Battery acid can cause burns. When working on or around batteries, wear protective clothing and safety glasses. Remove metal jewelry. Do not lay tools or metal objects on top of batteries.

Charging batteries generates explosive gases. **DO NOT CHARGE BATTERIES WHEN OPEN FLAMES OR SPARKS ARE PRESENT. DO NOT SMOKE.** Make sure the charger is turned off before disconnecting it from the machine. Charge the batteries in a well-ventilated area with the battery cover removed completely.

Maintenance and repairs must be performed by authorized personnel.

## **SAVE THESE INSTRUCTIONS**

# OPERATING INSTRUCTIONS

## **INSPECTION:**

Carefully unpack and inspect your burnisher for shipping damage. Each unit is tested and thoroughly inspected before shipment; any damage is the responsibility of the delivery carrier who should be notified immediately.

## **ELECTRICAL:**

This machine is battery operated and designed to operate on 36 volts DC (3) 12 volt batteries.

## **BATTERIES:**

Burnishers are shipped with batteries.

3 required - Part No. 956210 12V 210 AH 20 Hr. Rate

*We do not recommend mixing AMP hour capacities. Any alternate battery sets can be used if they equal physical size and capacity. See page 9 for service and installation.*

## **OPERATION:**

Before starting, familiarize yourself with the machine and its controls (see "Machine Overview" and "Control Panel" diagrams). To turn the machine ON, do the following:

1. Make sure the cover is on the machine so the safety interlock switch is in the closed position.
2. Make sure that no battery charger is plugged into the recharge port (there is also a safety interlock switch in this location).
3. Lift the red emergency disconnect button so it is in the up position.
4. Turn the keyswitch clockwise.

Once the initial functions listed above have been performed, press the “I” button on the control panel to turn the machine on. This will illuminate the “ON” light found on the control panel and activate the battery condition meter.

Before operating the machine, check the condition of the batteries. The battery condition meter can be read by looking at which light is illuminated on the meter. The green light on the right end of the meter indicates that the batteries are fully charged. As the batteries discharge, the light moves to the left. When the light under “1/2” is illuminated, the batteries are 1/2 charged. Once the meter shows approximately 1/4 charge, there is not enough power left in the batteries to start the burnishing motor and the batteries need to be recharged.

The machine can be used in either an “Automatic” mode or a “Manual” mode. In the “Automatic” mode, the burnishing head is automatically raised or lowered to compensate for irregularities in the floor. This produces an even finish. In the “Manual” mode, the height of the burnishing head is set by the operator. The head stays at this height until it is adjusted again by the operator. In either mode, the motion of the machine is controlled by the handles that are located on either side of the console. By squeezing the right handle against the console, the machine will move forward. By squeezing the left handle against the console, the machine will move backwards. The speed of the machine is controlled by the knob located on the control panel. The speed (in both directions) is increased by turning the knob clockwise.

The vertical array of five lights in the middle of the control panel under “Pad Pressure” gives an indication of pad pressure. The top light under the word “MIN” is illuminated when the pad is minimally touching the floor. The light directly above the word “MAX” is illuminated to give indication of the maximum amount of pad pressure. The remaining three lights designate varying levels of pad pressure between “MIN” and “MAX”. It is normal in “AUTOMATIC” mode for the lights to periodically “bounce” up and down on the display. This “bouncing” is a result of the machine encountering high and low areas in the floor. As a high spot is encountered, the lights will move down the array. If a low spot is encountered, the lights will move up the array. It is also normal for the motor to sound like it is slowing down over a high spot. If the motor did not slow down, there is a possibility that the floor finish could be damaged.

There are (2) circuit breakers at the bottom left rear corner of the machine. The top one (70A) is for the burnishing motor. The bottom one (18A) is for the traction drive. If the machine is not operating properly, check to see if the circuit breakers have popped. If so, depress the top of them to reset.

## ***AUTOMATIC MODE:***

To operate the burnishing motor in the “Automatic” mode, select one of the buttons located on the right side of the control panel under the word “Automatic”. The top button is for “light pad pressure”. The middle button is for “medium pad pressure”, and the bottom button is for “heavy pad pressure”. Caution should be used when operating the machine in the “heavy pad pressure” setting. If the machine is moved too slowly, there is a possibility that the floor finish will be damaged due to excessive pad pressure.

Once an automatic setting has been chosen, a light adjacent to that button will illuminate. A light under the word “Automatic” will also illuminate. The burnishing head will move to the “Start” position, which is approximately 2 inches above the floor. When the head is in this position, the burnishing motor will turn on when either of the direction handles is grasped and the machine begins to move. The pad will lower to engage the floor. The level of pad pressure is automatically maintained at the selected pressure setting. If the light under “Automatic” is flashing, the burnishing head is being adjusted to ensure the correct pad pressure is being maintained. When the light stops flashing, the head is no longer being adjusted up or down. If, while the machine is being used, a high spot or a low spot in the floor is encountered, the light will begin flashing and the height of the burnishing head will be adjusted to maintain the correct pad pressure. If the light does not stop flashing and the burnishing head is constantly being raised and lowered, the controller is having difficulty calibrating the machine to the floor conditions. Simply turn the speed down to a slower rate until the light stops flashing. When burnishing is complete, raise the head using the “UP” arrow under “MANUAL” on the control panel until it is in the full up position. The head will move slowly until it passes the “Start” position. At that point it will raise more rapidly.

## ***MANUAL MODE:***

To operate the burnishing motor in the Manual mode, press one of the arrow buttons on the control panel under the word “MANUAL” to control pad pressure. When the “UP” arrow is pressed, the burnishing head is raised. When the “DOWN” arrow is pressed, the head is lowered. When the Manual mode is selected, the light under the word “MANUAL” will illuminate. The pad will not spin unless the burnishing head is below the “Start” position. Pad pressure is indicated by the pad pressure indicator lights described above.

It is not advisable to operate the machine with the “MAX” light illuminated for an extended period of time as 1) damage to the floor finish could occur, and 2) the burnishing motor may stop spinning due to a circuit breaker trip.

*(Note: In the event the burnishing motor does stop spinning the operator should check the circuit breaker at the lower left rear corner of the machine to restart the motor)*

When burnishing is complete, raise the head using the “UP” arrow until it is in the full up position. The head will move slowly until it passes the “Start” position. At that point it will raise more rapidly.

### **SENSITIVITY ADJUSTMENTS:**

During use of the 2700 burnisher in the “Automatic” mode, the on-board controller constantly monitors the pad pressure on the floor. The first time the burnishing head is lowered, the light on the control panel under the word “Automatic” will blink. This alerts the operator that the machine is attempting to calibrate itself to the current floor condition. When the machine determines that the pad pressure level is adjusted properly, the light will quit blinking. This initial time frame when the light is blinking is called “First Time to Calibrate”.

When/If the current floor condition changes the light on the control panel under the word “Automatic” will again begin to blink to alert the operator that the machine is once again attempting to calibrate itself to the current floor condition.

There is a time delay which occurs between the machine sensing the change in the floor condition and actually making a change to its calibration settings. This time frame is called “Time to Recalibrate”. The light on the control panel under the word “Automatic” will not begin to blink during this time delay. If the “Time To Recalibrate” setting has been exceeded and the floor has not resumed its original condition then the machine will automatically begin to recalibrate itself.

When the current floor condition changes the light on the control panel under the word “Automatic” begins to blink to alert the operator that the machine is once again attempting to calibrate itself to the current floor condition. The machine will again automatically raise and lower the head until the proper calibration is found. When the new position is found, the light on the control panel under the word “Automatic” will quit blinking and the head will quit moving. The time frame when the light is again blinking and the burnishing head is moving is called “Second Time to Calibrate”.

As the machine is used over varying floor conditions, it will continually go through the “Time to Recalibrate” and “Second Time to Calibrate” cycle. Again, these are the operations that the machine performed:

- 1) “First Time to Calibrate” - The initial time frame when the machine is raising and lowering the burnishing head to find the correct position for proper pad pressure.
- 2) “Time to Recalibrate” - The time frame between when the machine senses a change in floor conditions and when it reacts to that change.
- 3) “Second Time to Calibrate” - All time frames after the initial one when the burnishing head is being raised or lowered to compensate for changing floor conditions.



The sensitivity of these three features can be changed to meet the needs of the floor that is being burnished. They can be made more sensitive, making the machine raise and lower the head more often to ensure that proper pad pressure is being maintained even over small changes in floor conditions. These features can also be made less sensitive, making the machine react less to changes in floor conditions. Making the machine less sensitive can be helpful if the location that is being burnished has particularly wavy floors and the machine can not keep up with the changing floor conditions. Care should be taken when changing the sensitivity. When the machine is too sensitive or not sensitive enough, there is a possibility that the floor finish can be damaged.

To change the sensitivity of the machine, the programming mode must be entered. To do this, press and hold the “OFF” button. Then press and hold the “UP” and “DOWN” buttons simultaneously. Then release the “OFF” button. Then release the “UP” and “DOWN” buttons. The machine is now in the programming mode. Notice that the “ON” light is now dimly blinking.

To change the “First Time to Calibrate” setting, after entering the programming mode, press and hold the “ON” button. Then press and hold the “DOWN” button. Release the “ON” button, then release the “DOWN” button. A combination of lights will illuminate in the pad pressure array. By pressing the “UP” or “DOWN” buttons, the lights will move accordingly. The closer the array is to the word “MIN”, the quicker the machine will calibrate itself. The closer the array is to the word “MAX”, the longer it will take for the machine to calibrate itself. During this time, the machine is finding an average floor height, therefore if the machine calibrates itself too quickly, it might not have a true representation of the floor. If the machine calibrates itself too slowly, it may never lock-in to an average. Once the correct sensitivity adjustment has been made, press the “OFF” button to exit the programming mode and save the setting.

To change the “Time to Recalibrate” setting, after entering the programming mode, press and hold the “ON” button. Then simultaneously press and hold the “Heavy Pad Pressure” and “Light Pad Pressure” buttons. Release the “ON” button and then simultaneously release the other two buttons.

A combination of lights will illuminate in the pad pressure array. By pressing the “UP” or “DOWN” buttons, the lights will move accordingly. The closer the lights are to the word “MIN” the quicker the machine will start to recalibrate itself after it encounters a high or low spot in the floor. The closer the lights are to the word “MAX”, the longer it will take for the machine to start to recalibrate itself after it encounters a high or low spot in the floor. Once the correct adjustment has been made, press the “OFF” button to exit the programming mode and save the setting.

To change the “Second Time to Calibrate” setting, after entering the programming mode, press and hold the “ON” button. Then press and hold the “Heavy Pad Pressure” button. Release the “ON” button, then release the “Heavy Pad Pressure” button. A combination of lights will illuminate in the pad pressure array. By pressing “UP” or “DOWN”, the lights will move accordingly. The closer the array is to the word “MIN”, the quicker the machine will recalibrate itself after the initial calibration level has been found. The closer the array is to the word “MAX”, the longer it will take for the machine to recalibrate itself. This functions just like the “first time to calibrate” described above. Once correct adjustment has been made, press “Off” button to exit the programming mode and save the setting.

To reset the machine back to its factory sensitivity settings, after entering the programming mode, press and hold the “Heavy Pad Pressure”, “Medium Pad Pressure”, and “Light Pad Pressure” buttons. Then release the “ON” button and then simultaneously release the other three buttons. Most of the lights on the control panel will blink at random. To reset to the factory settings, press the “UP” button and then press the “OFF” button to exit the programming mode.

Power to the control board must be disconnected to disable the programming mode. This can be most easily done by pressing the red emergency stop button. All values will be stored in the memory.

**CAUTION:** Machine will not be used on surfaces with a gradient exceeding 2%.

The machine shall be used only instructed and authorized persons. When cleaning, servicing or maintaining the machine, replacing parts or converting to another function the power source shall be switched off. Operated machines shall be disconnected by removing the power plug and battery-operated machines shall be disconnected by removing the key of the power switch or any other effective means.

Before use, all covers and doors shall be put in the position specified in the instructions for use.

For machines with traction drive and a mass exceeding 100 kg:

- In order to prevent unauthorized use of the machine the power source shall be switched off or locked, for example, by removing the key of the power switch.
- Machines left unattended shall be secured against unintentional movement.
- During operation attention shall be paid to other persons, especially children.

**AFTER USE:**

Turn machine off by pressing the “O” button on the control panel. Machine can be cleaned with a mild detergent and a damp cloth. Batteries should be charged after each use or when the battery condition meter shows a low charge. To recharge the batteries, plug the 36V charger into the recharge port located at the bottom right rear corner of the machine. The recharge port has an interlock switch so the machine can not be turned on when the batteries are being recharged. Once the meter on the battery charger reads 0 amps, the batteries are recharged. This should take approximately 6 hours if the batteries are completely discharged.

**PAD INSTALLATION:**

Using the “UP” arrow under “MANUAL”, raise the burnishing head to the full up position. Press the “O” button on the control panel to turn the machine off. Remove the center cup locking device by gripping on outer edges and turning clockwise. NOTE: center cup cannot be pulled out, it must be unscrewed. After removing used pad, place new pad on pad driver assembly using outer flange to center pad. Push center locking cup through pad and into pad driver assembly. The ratchet teeth on the center cup will engage into the pad driver assembly and should be pushed in as far as possible. If further tightening is needed, rotate the center locking cup counterclockwise.

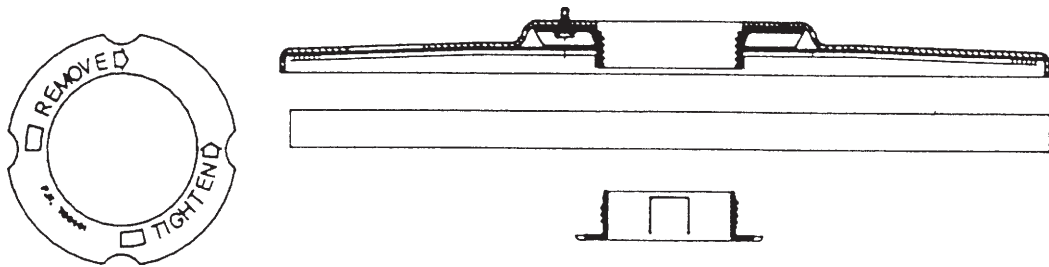

# **BATTERY SERVICE AND INSTALLATION:**

## **WARNING**

Battery acid can cause burns. When working on or around batteries, wear protective clothing and safety glasses. Remove metal jewelry. Do not lay tools or metal objects on top of batteries.

## **CHARGING OF BATTERIES:**

Charging batteries generates explosive gasses. DO NOT CHARGE BATTERIES WHEN OPEN FLAMES OR SPARKS ARE PRESENT. DO NOT SMOKE. Make sure the charger is turned off before disconnecting it from the batteries. Charge the batteries in a well-ventilated area. Fluid levels should be checked before and after charging and maintained at the proper levels. If the burnisher is not used for extended periods of time, batteries should be kept fully charged with a boost charge once a week.

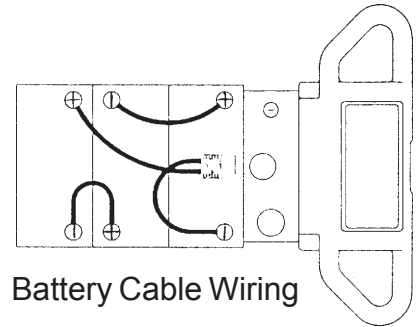

Battery Cable Wiring

## **CARBON BRUSH REPLACEMENT:**

Design life of carbon brushes is between 1800-2000 hours. Replace brushes if worn to 3/8" or less, broken, or chipped. All carbon brushes should be replaced when motor is serviced. 4 required, P/ N 572003. Red indicator on control panel will glow when carbon brush service is required.

## **CARBON BRUSH SERVICE:**

1. Disconnect batteries from machine.
2. Remove cover, filter, and collection tray from dust control assembly.
3. Remove two screws that hold dust control housing and motor cover to motor.
4. Push motor cover up and out of the way of the top of the motor.
5. Blow out top of motor with air line.
6. Loosen screw and remove carbon brush lead.
7. Slide brush spring off the back of carbon brush and remove brush.
8. Reverse order for installation.

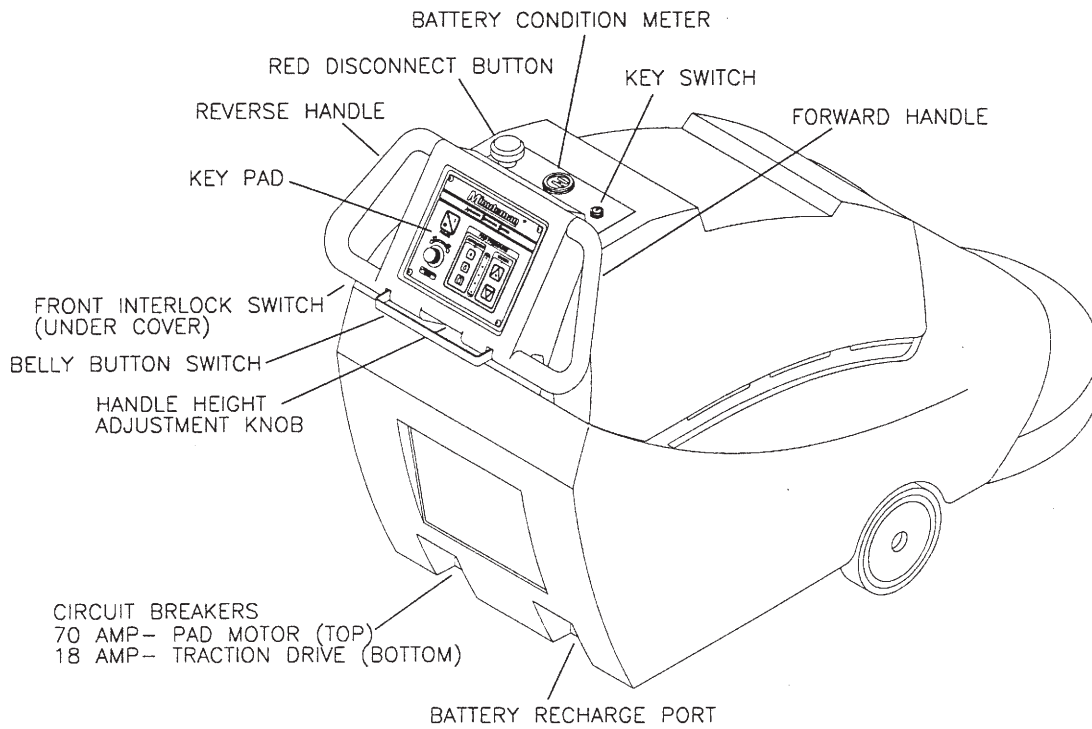

## MACHINE OVERVIEW

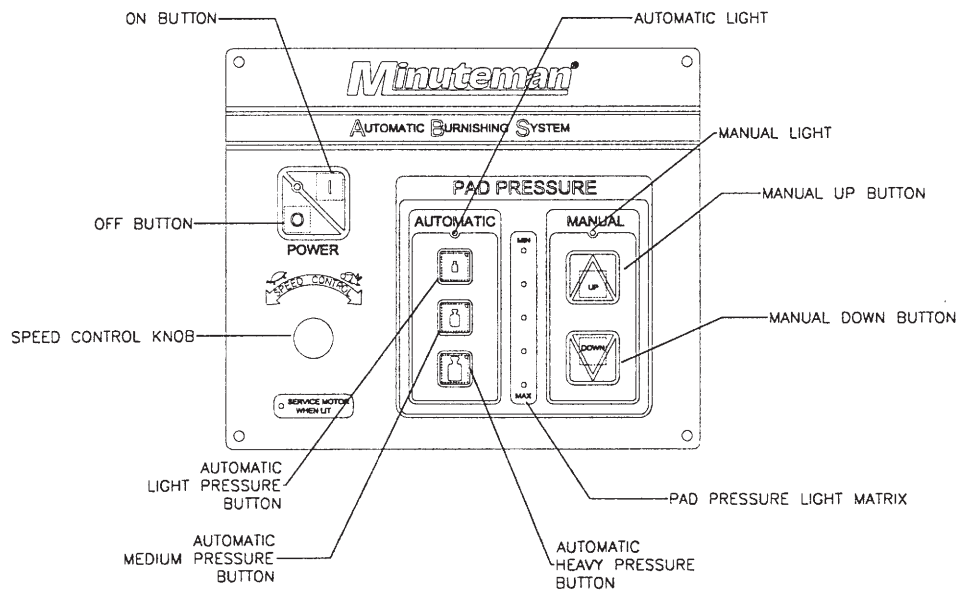

## CONTROL PANEL

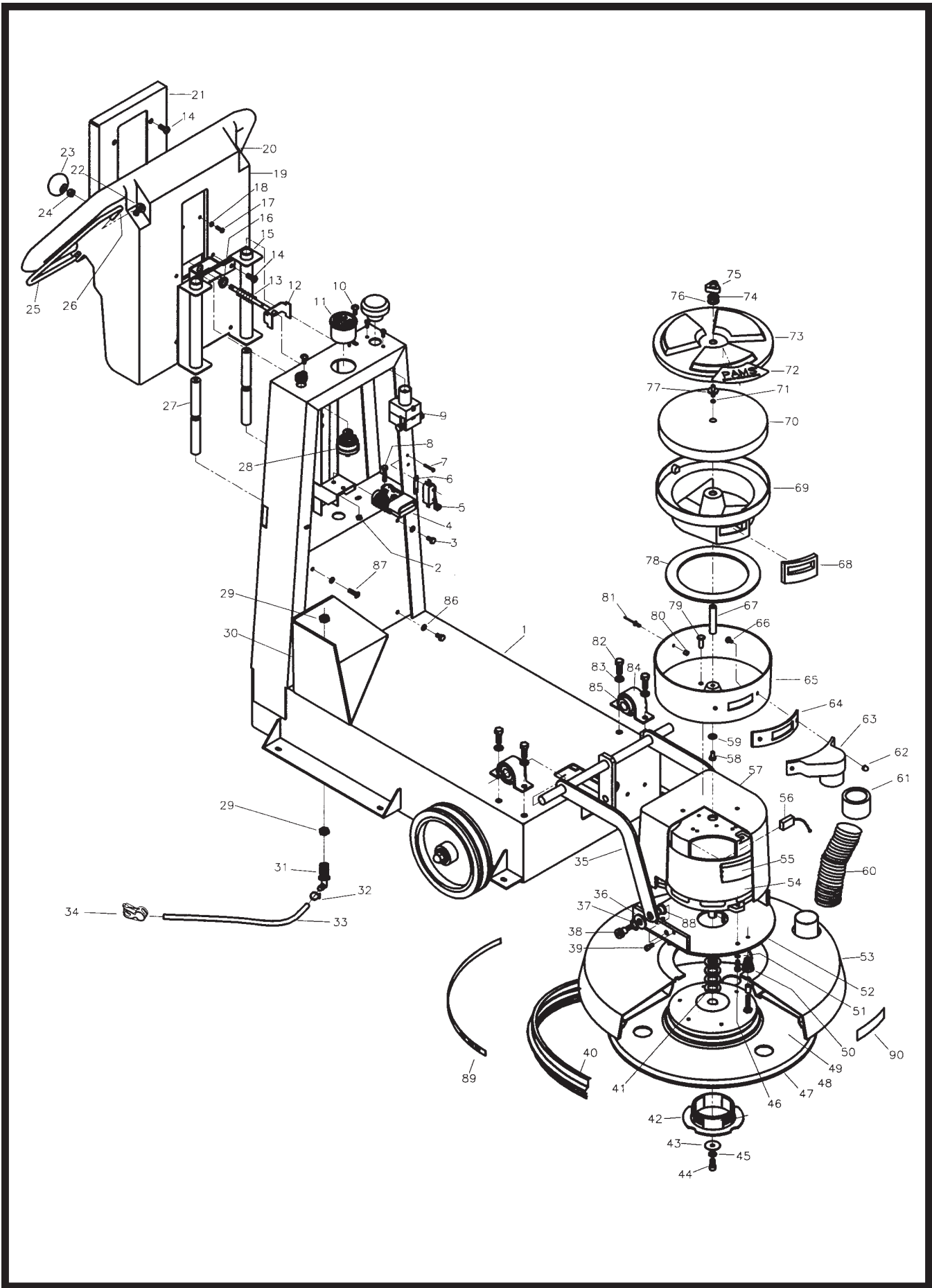

# Parts Listing

ITEM NO.	PART NO.	QTY.	DESCRIPTION	ITEM NO.	PART NO.	QTY.	DESCRIPTION
1	670035	1	Frame Weldment	46	713003	3	BLT-HH 1/4-20 x 1 #5
2	711373	2	1/4-20 Nyloc Nut	47	670075	1	Multi-Flex Pad Driver
3	710178	3	SCR-MC 1/4-20 x .50	48	762397	4	Leveler Bolt
4	740147	1	Charge Connector	49	670101	4	Spacer
5	740128	1	Switch	50	809857	4	Conical Spring
6	711430	1	Tinnerman Plate	51	711564	3	WSR-External Lock 1/4
7	710207	2	6-32 x .87 Screw	52	670047	1	Motor Plate Weldment
8	711210	2	1/4-20 x 1.25 HH Bolt	53	260559	1	Pad Shroud Assembly
9	742202	1	Disconnect Switch	54	742461	1	Motor 36V 2.5 HP
10	710180	4	SCR-MC 1/4-20 x .75	55	150209	1	Foam Tape
11	742310	1	Hour Meter	56	572003	4	Carbon Brush Replacement
12	670032	1	Release Rod Weldment	57	670014	1	Motor Cover
13	833102	1	Spring, Compression	58	711202	1	Bolt-HH 1/4-20 x .50
14	710197	6	SCR-MC 5/16-18 x .75 PHI	59	711505	1	WSR-Flat 1/4
15	670036	1	Handle Guide Weldment	60	670094	1	Dust Hose
16	260041	1	Bushing	61	762402	1	Hose Cuff
17	712822	2	Screw-THMS 10-24 x .500	62	711351	2	Nut-Acorn 10-32
18	711543	2	WSR-Helical #10	63	762131PTD	1	Hose Fitting
19	670010	1	Handle	62	762411	1	Gasket-Dust Collection Tray
20	670060	1	Wire Handle - Left	65	762396B	1	Filter Housing
21	670098	1	Handle Brace	66	710556	2	SCR-MC 10-32 x .75
22	829052	4	Nylon Flanged Bushing	67	762416PLT	1	Threaded Spacer
23	807385	1	Knob	68	762404	1	Filter Gasket
24	711381	1	Nut-Hex 1/2-13	69	762132	1	Dust Collection Tray
25	670033	1	Wire Handle - Right	70	762403	1	Filter Pad
26	711721	8	Retaining Ring	71	390061	1	O-Ring
27	670017	2	Handle Rail	72	715252	1	Decal-PAMS
28	741005	1	Key Switch	73	762415	1	Filter Housing Cover
29	260272	2	Nut-Nylon 1/4 NPT	74	711524	1	WSR-Wave .52 x .87 x .01
30	670013	1	Battery Box	75	833214	1	Knob, 1/4-20
31	320271	1	90° Nozzle Body	76	711594	1	WSR-Flat .56 x .88 x .03
32	450076	1	Crimp Clamp SS 185R	77	762409PLT	1	Threaded Pin Retainer
33	260224	1	Hose, Clear 18"	78	480049	1	Gasket
34	320273	1	Hose, Shut-Off Clamp	79	711144	2	SCR-ST-F 10-24 x .50
35	670119	1	Pivot Weldment	80	762410	1	Bushing .196 x .312 x .265
36	712310	2	WSR-Flat .52 x .87 x .06 STPL	81	711903	1	Rivet, Pop .19 x .25
37	711524	2	WSR-Wave .52 x .87 x .01	82	711241	4	BLT-HH 3/8-16 x .75
38	712122	2	SLD BLT 1/2 x 5/8	83	711546	4	WSR-Helical 3/8
39	710961	4	SCR-SC 1/4-20 x .37 ST NI	84	840049	2	Stamped STL Pillow Block
40	260595	1	Dust Skirt	85	881059	2	Bearing .75 ID W/L Collar
41	711512	6	WSR-Flat .75 x 1.37 x .08	86	711554	4	Internal Lock Washer
42	760401	1	Center Cup	87	710182	1	SCR MC 1/4-20 x 1.00
43	711516	1	WSR-Flat .31 x 1.25 x .05	88	670117	2	Flanged Bushing
44	710856	1	SCR-SC 5/16 - 24 x .62	89	230030	1	Band Clamp
45	711545	1	WSR-Helical 5/16	90	260598	6	Anti-Skid, Burnisher Skirt

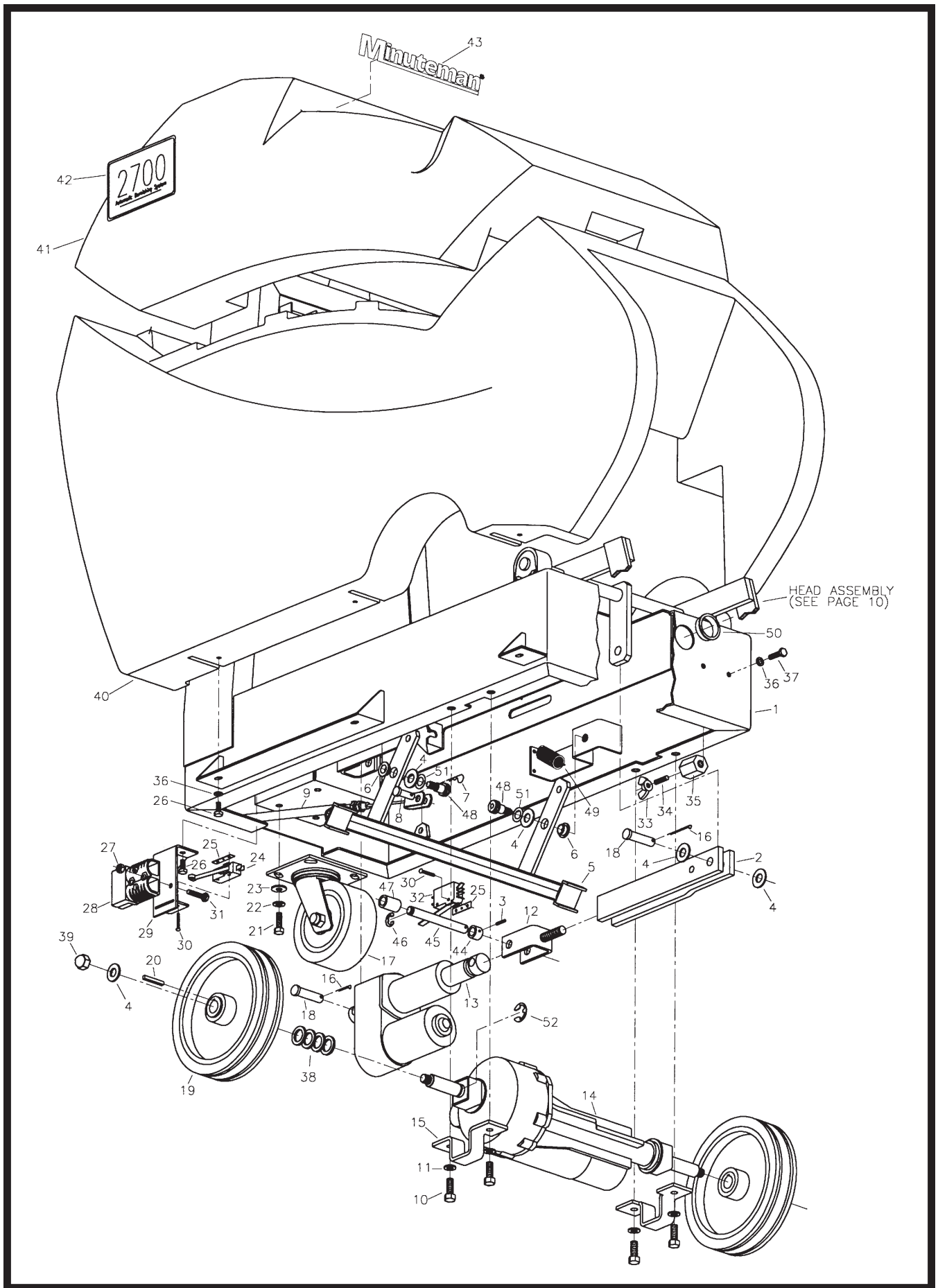



# Parts Listing

ITEM NO.	PART NO.	QTY.	DESCRIPTION
1	670035	1	Frame Weldment
2	670039	1	Linkage Arm Weldment
3	711615	1	Rollpin .12 x .75
4	711509	6	WSR-Flat .52 x 1.06 x .09
5	670051	1	Parking Brake Weldment
6	260041	2	Bushing
7	833374	1	Cotter Pin
8	711668	1	Clevis Pin 3/8 x 1
9	320210	1	Brake Cable Assembly
10	711241	4	Bolt-HH 3/8-16 x .75
11	711546	4	WSR-Helical 3/8
12	320140	1	Yoke Weldment
13	742459	1	Actuator
14	742460	1	Transaxle
15	670031	2	Transaxle Mount
16	380-532-20	2	Cotter Key
17	827110	1	Caster
18	712109	2	Clevis Pin 1/2 x 1.75
19	210141	2	Wheel 8"
20	361233	2	Key 3/16 Sq. x 1.50
21	711228	4	BLT-HH 5/16-18 X .75
22	711545	4	WSR-Helical 5/16
23	711575	4	WSR-Flat .31 x .75 x .06
24	740128	1	Switch
25	711430	2	Tinnerman Plate
26	711203	8	BLT-HH 1/4-20 x .62
27	711373	2	1/4-20 Nyloc Nut
28	740147	1	Charge Connector
29	361135	1	Charge Plug Bracket
30	710207	4	SCR-MC 6-32 x .87 STPL
31	711210	2	BLT-HH 1/4-20 x 1.25
32	833329	1	Switch
33	711368	2	Wing Nut 1/4-20
34	833638	2	Brass Stud
35	740132	2	Insulator-Glastic
36	711544	8	WSR-Helical 1/4
37	711202	2	BLT-HH 1/4-20 x .50
38	712318	8	WSR-Flat .75 x 1.12 x .12
39	670070	2	Acorn Nut 1/2-20
40	670011	1	Lower Body
41	670009	1	Cover
42	715251	2	Decal
43	715385	1	Decal, Minuteman
44	670055	1	Actuator Pin Sleeve
45	670054	1	Actuator Pin
46	711713	1	Retaining Ring-E Ext. .50
47	670069	2	Actuator Pin Spacer
48	712099PLT	2	BLT-Shoulder 1/2 x 1/2
49	760594	2	Extension Spring
50	670092	1	Heyco Bushing 1 1/2"
51	711524	2	WSR-Wave .52 x .87 x .01
52	809148	2	E-Ring .75

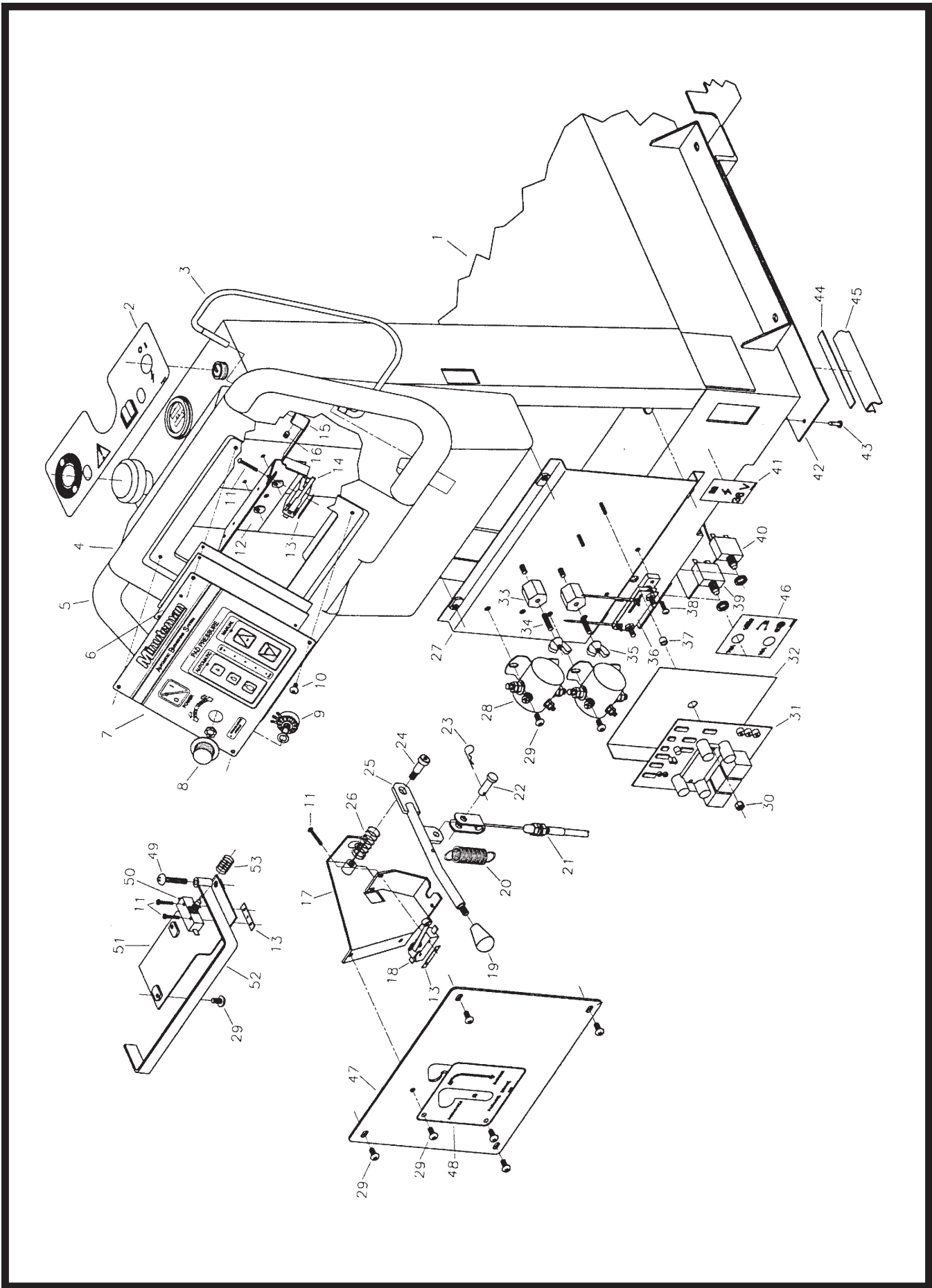

# Parts Listing

ITEM NO.	PART NO.	QTY.	DESCRIPTION
1	670035	1	Frame Weldment
2	715249	1	Decal-Instructions
3	670033	1	Wire Handle - Right
4	670060	1	Wire Handle - Left
5	670010	1	Handle Console
6	742476	1	Fuse 10A
7	742498	1	Control Board Assembly
8	809874	1	Knob
9	742471	1	Potentiometer Assembly
10	712822	4	SCR-THMS 10-24 x .500
11	710207	8	SCR 6-32 x .87
12	670044	1	Switch Bracket
13	711430	4	Tinnerman Clip
14	833329	2	Micro Switch
15	670062	2	Cam Assembly
16	711004	2	Set Screw 1/4-20 x .25
17	320198	1	Brake Bracket Weldment
18	740128	1	Snap Switch
19	760592	1	Knob
20	760594	1	Extension Spring
21	320210	1	Cable, Brake Assembly
22	711668	1	Clevis Pin 3/8 x 1.0
23	833374	1	Cotter Pin 7/64 x 1.0
24	712081	1	Shoulder Bolt 5/16
25	320205	1	Parking Brake Lever
26	833102	1	Compression Spring
27	670068	1	Electrical Panel
28	740243	2	Solenoid 36V 200A
29	710178	12	SCR-MC 1/4-20 x .50
30	711372	2	Nut-Nyloc 8-32
31	740803	1	Speed Control 36V
32	805637	1	Insulator
33	740132	2	Insulator- Glastic
34	833638	2	Brass Stud
35	711368	2	Wing Nut 1/4-20
36	742403	2	Calibrated Shunt
37	200340	2	Spacer
38	712536	2	SCR-MC 10-24 x .62
39	740131	1	Circuit Breaker 70A
40	740238	1	Circuit Breaker 18A
41	715246	1	Decal, 36V
42	670012	1	Bottom Shroud
43	711109	8	SCR-ST-B 12 x .50 STPL
44	760263	1	Foam Tape
45	260180	1	"U" Channel
46	715250	1	Decal, Circuit Breakers
47	670056	1	Access Panel
48	715255	1	Decal, Parking Brake
49	712569	1	SCR-MC 1/4-20 x 1.50
50	742472	1	Switch
51	670089	1	Switch Bracket
52	670088	1	Switch Lever
53	670093	1	Compression Spring

## A.B.S. ELECTRICAL INFORMATION

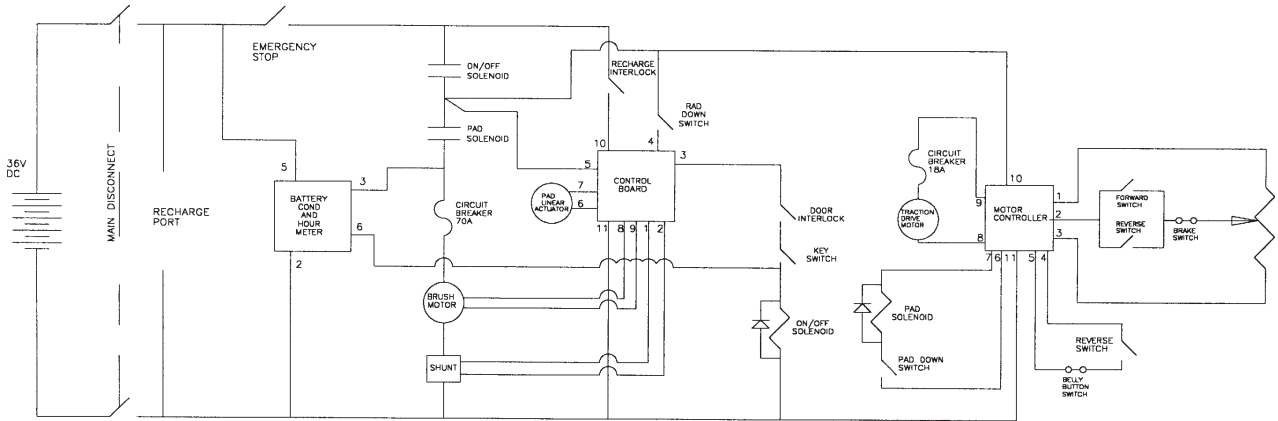

## SCHEMATIC DIAGRAM

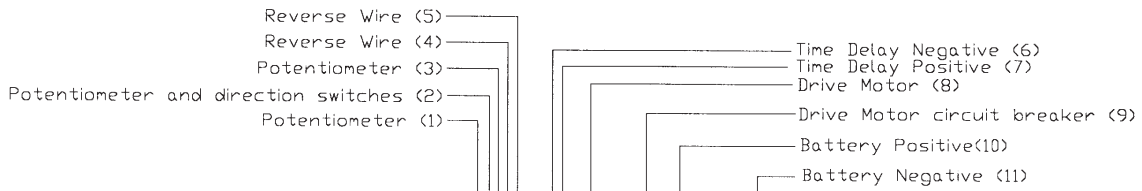

## I/O DIAGRAM - SPEED CONTROL BOARD







# LIMITED WARRANTY

Minuteman International, Inc. warrants to the original purchaser/user that this product is free from defects in workmanship and materials under normal use and service for a period of three years from date of purchase. In addition, Minuteman International, Inc. will, at its option, honor labor warranty claims for the first 12 months from date of sale, provided such claims are submitted through and approved by factory authorized repair stations. Minuteman International, Inc. will, at its option, repair or replace without charge, except for transportation costs, parts that fail under normal use and service when operated and maintained in accordance with the applicable operation and instruction manuals.

This warranty does not apply to normal wear, or to items whose life is dependent on their use and care, such as belts, cords, switches, hoses, rubber parts, electrical motor components or adjustments. Parts not manufactured by Minuteman International, Inc. such as engines, batteries, battery chargers, hydraulic pumps, and tires are covered by and subject to the warranties and/or guarantees of their manufacturers. Please contact Minuteman International, Inc. for procedures in warranty claims against these manufacturers.

**Special warning to purchaser** — Use of replacement filters and/or prefilters not manufactured by Minuteman International, Inc. or its designated licensees, will void all warranties expressed or implied.

A potential health hazard exists without exact original equipment replacement.

All warranted items become the sole property of Minuteman International, Inc. or its original manufacturer, whichever the case may be.

Minuteman International, Inc. disclaims any implied warranty, including the warranty of merchantability and the warranty of fitness for a particular purpose. Minuteman International, Inc. assumes no responsibility for any special, incidental or consequential damages.

This limited warranty is applicable only in the U.S.A. and Canada, and is extended only to the original user/purchaser of this product. Customers outside the U.S.A. and Canada should contact their local distributor for export warranty policies. Minuteman International, Inc. is not responsible for costs or repairs performed by persons other than those specifically authorized by Minuteman International, Inc. This warranty does not apply to damage from transportation, alterations by unauthorized persons, misuse or abuse of the equipment, use of non-compatible chemicals, or damage to property, or loss of income due to malfunctions of the product.

If a difficulty develops with this machine, you should contact the dealer from whom it was purchased.

This warranty gives you specific legal rights, and you may have other rights which vary from state to state. Some states do not allow the exclusion or limitation of special, incidental or consequential damages, or limitations on how long an implied warranty lasts, so the above exclusions and limitations may not apply to you.

## ***Minuteman***<sup>®</sup>

**World Headquarters**  
Minuteman International, Inc.  
111 South Rohlwing Road  
Addison, Illinois 60101

Minuteman Canada, Inc.  
2210 Drew Road  
Mississauga, Ontario  
L5S 1B1

(630) 627-6900  
FAX (630) 627-1130

(905) 673-3222  
FAX (905) 673-5161

986742  
Printed in U.S.A.